

# COMPOSANTES DE MOTEUR – ENGINE COMPONENTS

## ENSEMBLES DE JOINTS D'ÉTANCHÉITÉ / GASKET SETS

- Winderosa™ fabrique des joints d'étanchéité de très grande qualité pour l'industrie des moteurs 2-temps dans ses installations modernes, contrôlées par ordinateur, aux Etats-Unis.
- La vaste gamme de matériels de haute technologie de Winderosa™ leur procure une fiabilité et une performance inégalées pour rencontrer les exigences des moteurs contemporains.
- Winderosa™ distribue ses produits dans plus de 38 pays sur six continents. Cette exposition à différents types d'essence et de climats représente le test ultime dans le domaine.

---

|                                |   |
|--------------------------------|---|
| <b>ENS. COMPLET<br/>MOTEUR</b> | <b>ENSEMBLE PRO-FORMANCE<br/>AVEC PRÉFIXE "611"</b> |
|--------------------------------|---|

- Les ensembles avec préfixe "611" comprennent TOUS les joints d'étanchéité pour rebâtir professionnellement un moteur incluant les anneaux d'étanchéité d'huile de haute performance de Winderosa™.
- Les anneaux d'étanchéité d'huile de performance de Winderosa™ sont munis d'un ressort composé d'un alliage à teneur élevée Chrome / Acier inoxydable pour obtenir une performance maximale et une résistance à la corrosion.



- Winderosa™ manufactures high quality gaskets for the two cycle engine industry in its modern computer controlled facilities in the USA.
- Winderosa™ extensive range of high tech materials provide unmatched reliability and performance for the demanding needs of todays power plants.
- Winderosa™ distributes products to over 38 countries on six continents. This exposure to varying fuels and climates is the ultimate field test.

---

|                            |   |
|----------------------------|---|
| <b>ENGINE<br/>FULL SET</b> | <b>PRO-FORMANCE SET<br/>WITH "611" PREFIX</b> |
|----------------------------|---|

- Sets with "611" prefix contain ALL gaskets necessary for professional engine rebuilding including Winderosa™ high performance oil seals.
- Winderosa™ performance oils seals have a high chromium content stainless steel alloy spring for maximum performance and corrosion resistance

# COMPOSANTES DE MOTEUR – ENGINE COMPONENTS

## ENSEMBLES DE JOINTS D'ÉTANCHÉITÉ / GASKET SETS

- Winderosa™ fabrique des joints d'étanchéité de très grande qualité pour l'industrie des moteurs 2-temps dans ses installations modernes, contrôlées par ordinateur, aux Etats-Unis.
- La vaste gamme de matériels de haute technologie de Winderosa™ leur procure une fiabilité et une performance inégalées pour rencontrer les exigences des moteurs contemporains.
- Winderosa™ distribue ses produits dans plus de 38 pays sur six continents. Cette exposition à différents types d'essence et de climats représente le test ultime dans le domaine.

---

**ENS. COMPLET  
MOTEUR**

**ENSEMBLE PRO-FORMANCE  
AVEC PRÉFIXE "610"**

- Les ensembles avec préfixe "610" comprennent les joints d'étanchéité de haute performance de tête et de base, les joints d'admission et d'échappement ainsi que les joints tubulaires.
- Ces ensembles de performance sont spécialement conçus pour être utilisés lorsque vous devez remonter complètement la partie supérieure du moteur [cylindre(s)].



- Winderosa™ manufactures high quality gaskets for the two cycle engine industry in its modern computer controlled facilities in the USA.
- Winderosa™ extensive range of high tech materials provide unmatched reliability and performance for the demanding needs of todays power plants.
- Winderosa™ distributes products to over 38 countries on six continents. This exposure to varying fuels and climates is the ultimate field test.

---

**ENGINE  
FULL SET**

**PRO-FORMANCE SET  
WITH "610" PREFIX**

- Sets with "610" prefix contain High Performance head, base, intake, exhaust gaskets and O'rings.
- These performance seals are designed for total upper engine rebuild [cylinder(s)].

# COMPOSANTES DE MOTEUR – ENGINE COMPONENTS

## ENSEMBLES DE JOINTS D'ÉTANCHÉITÉ / GASKET SETS

| Modèle / Model                   | Année / Year | CC   | Cyl. | Ens. complet Cyl. Full top set | Ens. complet Moteur / Engine Full set |
|----------------------------------|--------------|------|------|--------------------------------|---------------------------------------|
| <b>KAWASAKI</b>                  |              |      |      |                                |                                       |
| JS300                            | 1986-91      | 295  | 1    | 610100                         | 611100                                |
| JS440                            | 1982-88      | 436  | 2    | 610101                         | 611101                                |
| JS440                            | 1989-92      | 436  | 2    | 610102                         | 611102                                |
| JS550                            | 1982-90      | 531  | 2    | 610103                         | 611103                                |
| JS550 SX                         | 1991-95      | 531  | 2    | 610402                         | 611402                                |
| JS650                            | 1986-96      | 635  | 2    | 610104                         | 611104                                |
| JH750 SS, Xi                     | 1993-99      | 743  | 2    | 610403                         | 611407                                |
| JH750 ZXi                        | 1995-97      | 743  | 2    | 610403                         | 611408                                |
| JS750 SS, SXi, PRO               | 1992-2002    | 743  | 2    | 610403                         | 611403                                |
| JT750 ST, STS, STX               | 1992-98      | 743  | 2    | 610403                         | 611407                                |
| JS800 SX                         | 2003-06      | 800  | 2    | 610409                         | 611409                                |
| JH900, JT900                     | 1995-2006    | 900  | 3    | 610404                         | 611404                                |
| JH1100, JT1100                   | 1996-2004    | 1071 | 3    | 610405                         | 611405                                |
| Ultra 130                        | 2004         | 1071 | 3    | 610405                         | 611405                                |
| Ultra 150                        | 1999         | 1176 | 3    | 610410                         | 611411                                |
| Ultra 150                        | 2000-05      | 1176 | 3    | 610410                         | 611410                                |
| 1200 STX-R                       | 2002-05      | 1176 | 3    | 610410                         | 611410                                |
| <b>POLARIS</b>                   |              |      |      |                                |                                       |
| SL650                            | 1992-95      | 650  | 3    | 610801                         | 611801                                |
| SL, SLT, SLH 700                 | 1996-2003    | 700  | 2    | 610804                         | 611804                                |
| 700 Hurricane, Virage            | 1996-2000    | 700  | 2    | 610804                         | 611804                                |
| 700 Virage, Freedom              | 2001-04      | 700  | 2    | 610811                         | 611811                                |
| SL, SLT 750                      | 1993-95      | 750  | 3    | 610802                         | 611802                                |
| Octane 777- stand up             | 2002-04      | 777  | 2    | 610807                         | 611807                                |
| Virage I                         | 2002-04      | 777  | 2    | 610808                         | 611808                                |
| SL, SLT, SLX 780                 | 1995-97      | 780  | 3    | 610803                         | 611803                                |
| SLX PRO 785                      | 1997-2000    | 785  | 3    | 610810                         | 611810                                |
| SL 900                           | 1996-97      | 900  | 3    | 610805                         | 611805                                |
| SL, SLTX 1050                    | 1996-99      | 1050 | 3    | 610806                         | 611806                                |
| SLXH 1050                        | 1998-99      | 1050 | 3    | 610806                         | 611806                                |
| 1200 Polaris                     | 1999-2000    | 1165 | 3    | 610809                         | 611809                                |
| 1200 Polaris                     | 2001-04      | 1165 | 3    | 610812                         | 611812                                |
| <b>SEA-DOO</b>                   |              |      |      |                                |                                       |
| 580 Moteur jaune / Yellow engine | 1988-91      | 580  | 2    | 610110                         | 611110                                |
| 580 Moteur blanc / White engine  | 1992-96      | 580  | 2    | 610200                         | 611200                                |
| 650                              | 1993-95      | 633  | 2    | 610201                         | 611201                                |
| 720                              | 1995-2004    | 718  | 2    | 610204                         | 611204                                |
| 800                              | 1995-99      | 782  | 2    | 610205                         | 611205                                |
| 800 RFI                          | 2000-05      | 782  | 2    | 610209                         | 611209                                |
| 951 (pas 97 / not 97)            | 1998-2000    | 951  | 2    | 610206                         | 611206                                |
| 951 DI                           | ---          | 951  | 2    | ---                            | 007-625                               |
| 4-Tec                            | (Tous / All) | ---  | ---  | ---                            | 007-626                               |
| <b>TIGERSHARK</b>                |              |      |      |                                |                                       |
| 640                              | 1993-99      | 639  | 2    | 610501                         | 611501                                |
| 770                              | 1996-99      | 768  | 2    | 610504                         | 611504                                |
| 900                              | 1995-96, 99  | 896  | 3    | 610502                         | 611502                                |
| 1000                             | 1997-98      | 999  | 3    | 610503                         | 611503                                |

# COMPOSANTES DE MOTEUR – ENGINE COMPONENTS

## ENSEMBLES DE JOINTS D'ÉTANCHÉITÉ / GASKET SETS

| Modèle / Model                             | Année / Year | CC   | Cyl. | Ens. complet Cyl. Full top set | Ens. complet Moteur / Engine Full set |
|--|--------------|------|------|--------------------------------|---------------------------------------|
| <b>WET JET</b>                             |              |      |      |                                |                                       |
| 440  | ---          | 436  | 2    | 610120                         | 611120                                |
| <b>YAMAHA</b>                              |              |      |      |                                |                                       |
| 500  | 1987-93      | 524  | 2    | 610114                         | 611114                                |
| 650  | 1990-96      | 633  | 2    | 610119                         | 611119                                |
| 700 Pro-VXR                                | 1993-94      | 701  | 2    | 610601                         | 611601                                |
| 700 Wave Blaster                           | 1993-95      | 701  | 2    | 610601                         | 611601                                |
| Wave Runner                                | 1993-97      | 701  | 2    | 610601                         | 611601                                |
| FX1  | 1994-95      | 701  | 2    | 610601                         | 611601                                |
| Super Jet                                  | 1994-95      | 701  | 2    | 610601                         | 611601                                |
| Wave Raider                                | 1996-98      | 701  | 2    | 610601                         | 611601                                |
| 701 62T Wave Raider                        | 1994-95      | 701  | 2    | 610602                         | 611602                                |
| Wave Runner                                | 1999-2002    | 701  | 2    | 610602                         | 611602                                |
| Wave Venture                               | 1995-98      | 701  | 2    | 610602                         | 611602                                |
| 701 61X Super Jet                          | 1996-2004    | 701  | 2    | 610605                         | 611605                                |
| Wave Blaster                               | 1996         | 701  | 2    | 610605                         | 611605                                |
| 760 Tous / All                             | 1996-2000    | 760  | 2    | 610603                         | 611603                                |
| 800 GP 800, XL800                          | 1998-2005    | 784  | 2    | 610607                         | 611607                                |
| 1100, 1100 Wave Raider                     | 1995-97      | 1050 | 3    | 610604                         | 611604                                |
| 1100, 1100 Wave Venture                    | 1996-97      | 1050 | 3    | 610604                         | 611604                                |
| 1200 Yamaha 1200                           | 1997-2004    | 1131 | 3    | 610606                         | 611606                                |
| 1200 Moteur à soupape / Power valve engine | 1999-2005    | 1176 | 3    | 610608                         | 611608                                |

## JOINTS D'ADMISSION – INTAKE GASKETS

Fig. 1

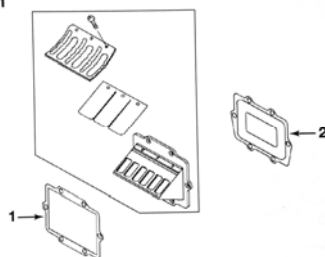

1. \*  
2. \*\*

| Modèle / Model  | Année / Year | Description                              | Qté req. Req'd qty | # Origine / OEM # | # Pièce / Part # |
|---|--------------|--|--------------------|-------------------|------------------|
| <b>KAWASAKI</b>   |              |  |                    |                   |                  |
| 300 SX Carburateur simple / Single carburetor Mikuni BN34/28mm  | 1986-91      | Pour carburateur / For carburetor.       | 2                  | 11009-3786        | 007-494          |
|   |              | Coupe flamme / Flame arrestor            | 2                  | 11060-3702        | 007-492          |
|   |              | Reed Valve                               | 2                  | 11060-3703        | 007-499          |
| 440 SX Carburateur simple / Single carburetor Mikuni BN 38/34mm | 1977-92      | Pour carburateur / For carburetor.       | 3                  | 11009-3786        | 007-494          |
|   |              | Coupe flamme / Flame arrestor            | 2                  | 11060-3702        | 007-492          |
|   |              | Collecteur d'admission / Intake manifold | 2                  | 11009-3785        | 007-501          |
| 550 SX Carburateur simple / Single carburetor Mikuni BN44/40mm  | 1987-90      | Pour carburateur / For carburetor.       | 2                  | 11009-3056        | 007-493          |
|   |              | Coupe flamme / Flame arrestor            | 1                  | 11009-3057        | 007-496          |
|   |              | Collecteur d'admission / Intake manifold | 2                  | 11009-3785        | 007-501          |
| 550 SX Carburateur simple / Single carburetor Keihin CDK 38mm   | 1991-95      | Pour carburateur / For carburetor.       | 1                  | 11060-3716        | 007-487          |
|   |              | Pour valve Reed / For Reed valve         | 2                  | 11009-3787        | 007-511          |
|   |              | Collecteur d'admission / Intake manifold | 2                  | 11009-3788        | 007-540          |

# COMPOSANTES DE MOTEUR – ENGINE COMPONENTS

## JOINTS D'ADMISSION – INTAKE GASKETS

| Modèle / Model  | Année<br>Year   | Description  | Qté req.<br>Req'd qty | # Origine<br>/ OEM # | # Pièce<br>Part # |
|---|-----------------|--|-----------------------|----------------------|-------------------|
| <b>KAWASAKI</b>   |                 |  |                       |                      |                   |
| 650 SC, SX, X2<br>Keihin simple / Single Keihin<br>CDK 38/32mm                                    | 1991-95         | Pour carburateur / For carburetor.                         | 1                     | 11060-3716           | <b>007-487</b>    |
|   |                 | Pour valve Reed / For Reed valve                           | 4                     | 11060-3703           | <b>007-499</b>    |
| 650 SX Carburateur simple<br>/Single carburetor Keihin<br>28mm                                    | 1987-90         | Pour carburateur / For carburetor.                         | 1 (metal)             | 11009-3747           | <b>007-498</b>    |
|   |                 | Pour carburateur / For carburetor.                         | 1(fibre/fiber)        | ---                  | <b>007-498-01</b> |
|   |                 | Coupe flamme / Flame arrestor                              | 3                     | 11009-3727           | <b>007-495</b>    |
|   |                 | Pour valve Reed / For Reed valve                           | 4                     | 11009-3703           | <b>007-499</b>    |
| 650 TS Carburateur simple<br>/Single carburetor Keihin<br>28mm                                    | 1989-90         | Pour carburateur / For carburetor.                         | 1 (metal)             | 11009-3753           | <b>007-498</b>    |
|   |                 | Pour carburateur / for carburetor.                         | 1(fibre/fiber)        | ---                  | <b>007-498-01</b> |
|   |                 | Pour valve Reed / For Reed valve                           | 4                     | 11009-3703           | <b>007-499</b>    |
| 650 TS Carburateur simple<br>/Single carburetor Keihin<br>CDK 38 / 32mm                           | 1991-95         | Pour carburateur / For carburetor.                         | 1                     | 11060-3716           | <b>007-487</b>    |
|   |                 | Pour valve Reed / For Reed valve                           | 4                     | 11060-3703           | <b>007-499</b>    |
| 650 X2 Carburateur simple<br>/Single carburetor Keihin<br>28mm                                    | 1989-90         | Pour carburateur / For carburetor.                         | 1 (metal)             | 11009-3747           | <b>007-498</b>    |
|   |                 | Pour carburateur / For carburetor.                         | 1(fibre/fiber)        | ---                  | <b>007-498-01</b> |
|   |                 | Pour valve Reed / For Reed valve                           | 4                     | 11060-3703           | <b>007-499</b>    |
| 750 SS<br>750 SXXI<br>750 ST<br>750 SX<br>750 XiR<br>Keihin CDK 40 / 34mm<br>38mm simple / single | 1992-97         | Pour carburateur / For carburetor.                         | 1(fibre/fiber)        | 11060-3716           | <b>007-487</b>    |
|   | 1993-97         |  |                       |                      |                   |
|   | 1994-95         |  |                       |                      |                   |
|   | 1992-95         | Pour valve Reed / For Reed valve                           | 4                     | 11060-3717           | <b>007-563</b>    |
|   | 1994            |  |                       |                      |                   |
| 750 SXXi<br>750 STS, ZXI<br>750 SXI<br>750 STX<br>750 Xi-Sport<br>Keihin CDK II 40                | 1993-97         | Pour carburateur / For carburetor.                         | 2(fibre/fiber)        | 11060-3758           | <b>007-487</b>    |
|   | 1995-97         | Pour valve Reed au boîtier / For Reed valve to case        | 2                     | 11060-3717           | <b>007-563*</b>   |
|   | 1995-96         | Pour valve Reed au collecteur / For Reed valve to manifold | 2                     | 11060-3757           | <b>007-309**</b>  |
|   | 1998<br>1998-99 |  |                       |                      |                   |
| 750 SXi Pro<br>800 SX-R<br>Mikuni 40mm  | 1998-02         | Pour carburateur / For carburetor.                         | 2                     | 11060-3761           | <b>007-575</b>    |
|   |                 | Pour valve Reed au boîtier / For Reed valve to case        | 2                     | 11060-3717           | <b>007-563*</b>   |
|   |                 | Pour valve Reed au collecteur / For Reed valve to manifold | 2                     | 11060-3757           | <b>007-309**</b>  |
| 900 STS<br>900 STX<br>900 ZXI<br>Triple Keihin CDK II<br>38mm                                     | 2001-02         | Pour carburateur / For carburetor.                         | 1                     | 11060-3753           | <b>007-311</b>    |
|   | 1997-04         | Pour valve Reed au boîtier / For Reed valve to case        | 2                     | 11060-3717           | <b>007-563*</b>   |
|   | 1995-97         | Pour valve Reed au collecteur / For Reed valve to manifold | 2                     | 11060-3757           | <b>007-309**</b>  |
|   |                 |  |                       |                      |                   |
| 1100 STX DI   | 2000-03         | Pour valve Reed / For Reed valve                           | 3                     | 11060-3717           | <b>007-563*</b>   |
| 1100 Ultra 130 DI   | 2001-04         | Pour valve Reed / For Reed valve                           | 3                     | 11060-3757           | <b>007-309**</b>  |
| 1100 STX<br>1100 ZXi<br>Carburateur triple./ Triple<br>carburetor- Keihin 38mm                    | 1997-99         | Pour carburateur / For carburetor.                         | 3                     | 11060-3776           | <b>007-331</b>    |
|   | 1996-03         | Pour valve Reed / For Reed valve                           | 3                     | 11060-3717           | <b>007-563*</b>   |
|   |                 | Pour valve Reed / For Reed valve                           | 3                     | 11060-3757           | <b>007-309**</b>  |
| 1200 STX-R  | 2002-04         | Pour carburateur / For carburetor.                         | 3                     | 11060-3776           | <b>007-331</b>    |
| 1200 Ultra 150  | 1999-04         | Pour valve Reed / For Reed valve                           | 3                     | 11060-3717           | <b>007-563*</b>   |
| Carburateur triple./ Triple<br>carburetor- Keihin 38mm  |                 | Pour valve Reed / For Reed valve                           | 3                     | 11060-3757           | <b>007-309**</b>  |

# COMPOSANTES DE MOTEUR – ENGINE COMPONENTS

## JOINTS D'ADMISSION – INTAKE GASKETS

| Modèle / Model | Année / Year | Description                              | Qté req. / Req'd qty | # Origine / OEM # | # Pièce / Part #  |
|----------------|--------------|--|----------------------|-------------------|-------------------|
| <b>POLARIS</b> |              |  |                      |                   |                   |
| 650 / 750      | ---          | Pour carburateur / For carburetor.       | 3                    | 3240128           | <b>007-494</b>    |
|                |              | Pour valve Reed / For Reed valve         | 6                    | 3084148           | <b>007-534</b>    |
|                |              | Coupe flamme / Flame arrestor            | 3                    | 5830013           | <b>007-536</b>    |
| 700            | ---          | Pour carburateur / For carburetor.       | 2                    | 5830043           | <b>007-487-02</b> |
|                |              | Coupe flamme / Flame arrestor            | 2                    | 5830062           | <b>007-487-01</b> |
| 780            | ---          | Pour carburateur / For carburetor.       | 3                    | 3240128           | <b>007-494</b>    |
|                |              | Pour valve Reed / For Reed valve         | 9                    | 3084148           | <b>007-534</b>    |
|                |              | Coupe flamme / Flame arrestor            | 3                    | 5830013           | <b>007-536</b>    |
| 800            | ---          | Pour carburateur / For carburetor.       | 2                    | 5830043           | <b>007-487-02</b> |
|                |              | Carburateur supérieur / Upper carburetor | 2                    | 5830062           | <b>007-487-01</b> |
| 900 / 1050     | ---          | Pour carburateur / for carburetor.       | 3                    | 5830043           | <b>007-487-02</b> |
|                |              | Coupe flamme / Flame arrestor            | 3                    | 5830062           | <b>007-487-01</b> |
| 1200           | ---          | Pour carburateur / For carburetor.       | 2                    | 5830043           | <b>007-487-02</b> |

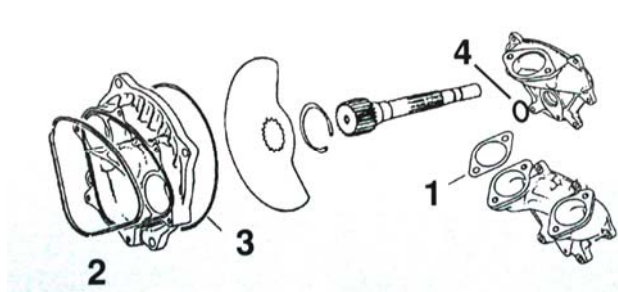

Figure # 1 \*

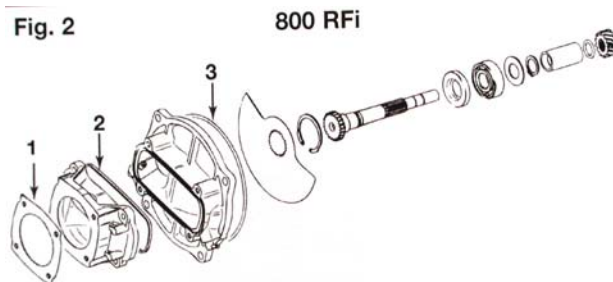

Figure # 2

| Modèle / Model         | Année / Year | Description   | Qté req. / Req'd qty | # Origine / OEM # | # Réf. / Ref. # | # Pièce / Part # |
|------------------------|--------------|---|----------------------|-------------------|-----------------|------------------|
| <b>SEA-DOO</b>         |              |   |                      |                   |                 |                  |
| 580                    | 1990-91      | Pour carburateur / For carburetor.                                    | 1                    | 290-850-372       | 1               | <b>007-494</b>   |
| 580 GTS                | 1992-96      | Pour rondelle avant du couvercle rotatif / Rotary cover front O-ring  | 1                    | 290-850-160       | 2               | <b>008-605</b>   |
| 580 SP                 | 1995         |   |                      |                   |                 |                  |
| 580 SPI                | 1995-96      | Pour rondelle arrière du couvercle rotatif / Rotary cover rear O-ring | 1                    | 293-300-023       | 3               | <b>008-610</b>   |
| 580 XP                 | 1991-92      |   |                      |                   |                 |                  |
| Simple carb. Mikuni    |              | Pour rondelle à injection à l'huile / Oil injection O-ring            | 1                    | 293-300-018       | 4               | <b>008-587</b>   |
| 38 Single carb.        |              |   |                      |                   |                 |                  |
| 580 GTX                | 1992-93      | Pour carburateur / For carburetor.                                    | 1                    | 290-850-373       | 1               | <b>007-494</b>   |
| 580 SP                 | 1991-94      | Pour rondelle avant du couvercle rotatif / Rotary cover front O-ring  | 1                    | 290-831-705       | 2               | <b>008-608</b>   |
| 580 SPI                | 1993-94      |   |                      |                   |                 |                  |
| 580 / 650 SPX          | 1993         | Pour rondelle arrière du couvercle rotatif / Rotary cover rear O-ring | 1                    | 293-300-023       | 3               | <b>008-610</b>   |
| 650 XP                 | 1993-94      |   |                      |                   |                 |                  |
| Simple carb. Mikuni 38 |              | Pour rondelle à injection à l'huile / Oil injection O-ring            | 1                    | 293-300-018       | 4               | <b>008-587</b>   |
| Single carb.           |              |   |                      |                   |                 |                  |

# COMPOSANTES DE MOTEUR – ENGINE COMPONENTS

## JOINTS D'ADMISSION – INTAKE GASKETS

| Modèle / Model  | Année / Year       | Description   | Qté req. / Req'd qty | # Origine / OEM # | # Réf. / Ref. # | # Pièce / Part #  |
|---|--------------------|---|----------------------|-------------------|-----------------|-------------------|
| <b>SEA-DOO</b>  |                    |   |                      |                   |                 |                   |
| 650 GTX<br>Carb. double / Dual<br>Carb. Mikuni 38mm                         | 1995               | Pour carburateur / For carburetor.                                    | 2                    | 290-850-373       | 1               | <b>007-494</b>    |
|   |                    | Pour rondelle avant du couvercle rotatif / Rotary cover front O-ring  | 1                    | 290-931-440       | 2               | <b>008-606</b>    |
|   |                    | Pour rondelle arrière du couvercle rotatif / Rotary cover rear O-ring | 1                    | 290-300-023       | 3               | <b>008-610</b>    |
|   |                    | Pour rondelle à injection à l'huile / Oil injection O-ring            | 1                    | 293-300-018       | 4               | <b>008-587</b>    |
| 650 SPX   | 1995               | Pour carburateur / For carburetor.                                    | 2                    | 270-000-114       | 1               | <b>007-574-01</b> |
| 650 XPI<br>Mikuni 39mm carburateur double / Dual carburetor.                | 1994               | Pour carburateur / For carburetor.                                    | 2                    | 270-000-114       | 1               | <b>007-574-01</b> |
|   |                    | Pour rondelle avant du couvercle rotatif / Rotary cover front O-ring  | 1                    | 290-831-705       | 2               | <b>008-608</b>    |
|   |                    | Pour rondelle arrière du couvercle rotatif / Rotary cover rear O-ring | 1                    | 293-300-023       | 3               | <b>008-610</b>    |
|   |                    | Pour rondelle à injection à l'huile / Oil injection O-ring            | 1                    | 293-300-018       | 4               | <b>008-587</b>    |
| 720 GTi, HX, SPX, XP<br>Mikuni 39mm Carb. double / Dual carb.               | 1995-96            | Pour rondelle avant du couvercle rotatif / Rotary cover front O-ring  | 1                    | 290-931-440       | 2               | <b>008-606</b>    |
|   |                    | Pour rondelle arrière du couvercle rotatif / Rotary cover rear O-ring | 1                    | 290-300-023       | 3               | <b>008-610</b>    |
|   |                    | Pour rondelle à injection à l'huile / Oil injection O-ring            | 1                    | 293-300-018       | 4               | <b>008-587</b>    |
| 720 GS,Gsi, GTS, Gti<br>Mikuni 39mm carburateur simple / single carburetor. | 1997-98            | Pour carburateur / For carburetor.                                    | 2                    | 293-250-070       | 1               | <b>007-574-01</b> |
|   |                    | Pour rondelle avant du couvercle rotatif / Rotary cover front O-ring  | 1                    | 290-850-160       | 2               | <b>008-605</b>    |
|   |                    | Pour rondelle arrière du couvercle rotatif / Rotary cover rear O-ring | 1                    | 293-300-023       | 3               | <b>008-610</b>    |
|   |                    | Pour rondelle à injection à l'huile / Oil injection O-ring            | 1                    | 293-300-018       | 4               | <b>008-587</b>    |
| 720 SP<br>Mikuni carburateur simple / Single carburetor                     | 1997               | Pour carburateur / For carburetor.                                    | 2                    | 290-850-373       | 1               | <b>007-494</b>    |
|   |                    | Pour rondelle avant du couvercle rotatif / Rotary cover front O-ring  | 1                    | 290-850-160       | 2               | <b>008-605</b>    |
|   |                    | Pour rondelle arrière du couvercle rotatif / Rotary cover rear O-ring | 1                    | 293-300-023       | 3               | <b>008-610</b>    |
|   |                    | Pour rondelle à injection à l'huile / Oil injection O-ring            | 1                    | 293-300-018       | 4               | <b>008-587</b>    |
| 800 XP<br>800 GSX, GTX<br>Carb. double / Dual carb.<br>Mikuni 40mm          | 1995               | Pour carburateur / For carburetor.                                    | 2                    | 293-250-042       | 1               | <b>007-574-01</b> |
|   | 1996               | Pour rondelle du couvercle rotatif / Rotary cover O-ring              | 1                    | 290-831-765       | 3               | <b>008-618</b>    |
|   | ---                |   |                      |                   |                 |                   |
| 800 GSX Rfi<br>GTX Rfi  | 1999-01<br>1998-02 | Pour corps de papillon / Throttle body gasket.                        | 1                    | 293-250-071       | 1 / fig.2       | <b>007-574-02</b> |
|   |                    | Pour rondelle avant du couvercle rotatif / Rotary cover front O-ring  | 1                    | 420-850-520       | 2 / fig.2       | <b>008-615</b>    |
|   |                    | Pour rondelle arrière du couvercle rotatif / Rotary cover rear O-ring | 1                    | 420-831-767       | 3 / fig.2       | <b>008-615-01</b> |
| 951 Double carburateur 50mm / Dual carburetor 50mm                          | ---                | Joint du support de carburateur / Carburetor mounting gasket          | 2                    | 270-500-384       | 2               | <b>007-524-01</b> |

# COMPOSANTES DE MOTEUR – ENGINE COMPONENTS

## JOINTS D'ADMISSION – INTAKE GASKETS

| Modèle / Model     | Année / Year | Description                             | Qté req. / Req'd qty | # Origine / OEM # | # Réf. / Ref. # | # Pièce / Part #  |
|--------------------|--------------|---|----------------------|-------------------|-----------------|-------------------|
| <b>TIGER SHARK</b> |              |   |                      |                   |                 |                   |
| 640 / 770          | ---          | Pour carburateur / For carburetor.      | 1                    | 0673-090          | ---             | <b>007-524</b>    |
|                    |              | Pour valve Reed / For Reed valve        | 4                    | 3008-076          | ---             | <b>007-538</b>    |
|                    |              | Pour filtre à air. / Air cleaner gasket | 2                    | 3008-058          | ---             | <b>007-538-01</b> |
| 900 / 1000 / 1100  | ---          | Pour carburateur / For carburetor.      | 3                    | 3008-057          | ---             | <b>007-524</b>    |
|                    |              | Pour valve Reed / For Reed valve        | 3                    | 3008-076          | ---             | <b>007-538</b>    |
|                    |              | Pour filtre à air. / Air cleaner gasket | 3                    | 1673-091          | ---             | <b>007-538-03</b> |

Fig. 1

650/701

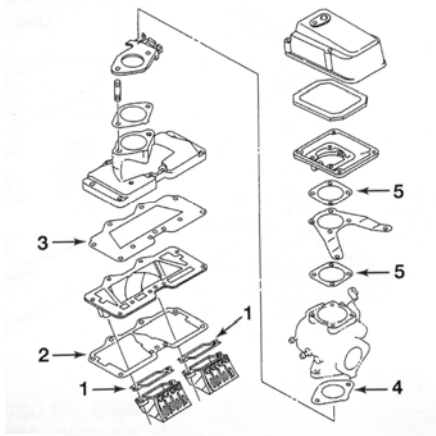
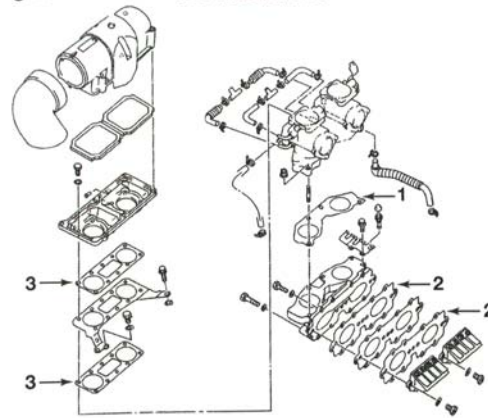

Fig. 2

701 Raider/760



| Modèle / Model   | Année / Year | Description                              | Qté req. / Req'd qty | # Origine / OEM # | # Réf. / Ref. # | # Pièce / Part # |
|--|--------------|--|----------------------|-------------------|-----------------|------------------|
| <b>YAMAHA</b>  |              |  |                      |                   |                 |                  |
| 500  | Toutes / All | Pour carburateur / For carburetor.       | 2                    | 6K8-13556-A2      | ---             | <b>007-494</b>   |
|  |              | Collecteur d'admission / Intake manifold | 1                    | 6K8-13621-A1      | ---             | <b>007-481</b>   |
|  |              | Coupe flamme / Flame arrestor            | 1                    | 6K8-13674-A1      | ---             | <b>007-483</b>   |
| 650 (6M6) (figure 1)<br>Mikuni simple 44mm /<br>Single Mikuni 44mm | Toutes / All | Pour carburateur / For carburetor.       | 1                    | 6M6-13556-A1      | 4               | <b>007-526</b>   |
|  |              | Collecteur d'admission / Intake manifold | 1                    | 6M6-13566-A2      | 2               | <b>007-484</b>   |
|  |              | Collecteur d'admission / Intake manifold | 1                    | 6M6-13563-A1      | 3               | <b>007-485</b>   |
|  |              | Pour valve Reed / For Reed valve         | 2                    | 6M6-13621-00      | 1               | <b>007-527</b>   |
|  |              | Coupe flamme / Flame arrestor            | 2                    | 6M6-13674-00      | 5               | <b>007-528</b>   |

# COMPOSANTES DE MOTEUR – ENGINE COMPONENTS

## JOINTS D'ADMISSION – INTAKE GASKETS

Fig. 1 650/701

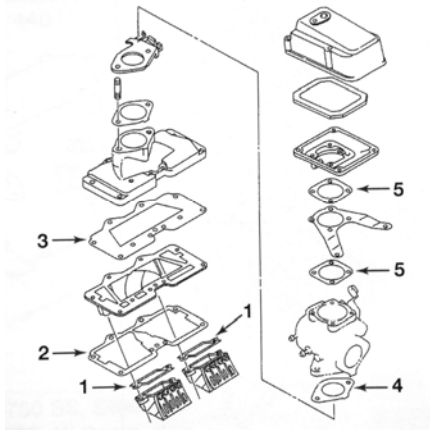
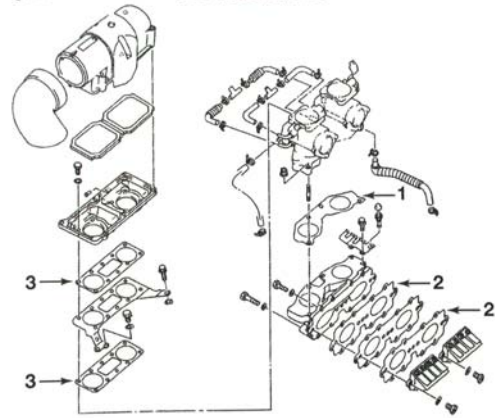

Fig. 2 701 Raider/760



| Modèle / Model       | Année / Year | Description  | Qté req. / Req'd qty | # Origine / OEM # | # Réf. / Ref. # | # Pièce / Part #  |
|----------------------|--------------|--|----------------------|-------------------|-----------------|-------------------|
| <b>YAMAHA</b>        |              |  |                      |                   |                 |                   |
| 701 (61X) (figure 1) | ---          | Pour carburateur / For carburetor.                             | 2                    | 6M6-13556-00      | 4               | <b>007-526</b>    |
|                      |              | Collecteur d'admission / Intake manifold                       | 1                    | 61X-13563-A1      | 3               | <b>007-561</b>    |
|                      |              | Collecteur d'admission / Intake manifold                       | 1                    | 61X-13566-A1      | 2               | <b>007-562</b>    |
|                      |              | Pour valve Reed / For Reed valve                               | 2                    | 61X-13621-A0      | 1               | <b>007-560</b>    |
| 701 (62T) (figure 2) | ---          | Coupe flamme / Flame arrestor                                  | 2                    | 6M6-13674-00      | 5               | <b>007-528</b>    |
|                      |              | Pour carburateur / For carburetor.                             | 1                    | 62T-13556-00      | 2               | <b>007-558</b>    |
|                      |              | Pour valve Reed / For Reed valve                               | 2                    | 62T-13566-00      | 1               | <b>007-577</b>    |
| 760 (figure 2)       | Toutes / All | Coupe flamme / Flame arrestor                                  | 2                    | 62T-13674-00      | 3               | <b>007-528-01</b> |
|                      |              | Pour carburateur / for carburetor.                             | 1                    | 64X-13556-00      | 1               | <b>007-351</b>    |
|                      |              | Pour valve Reed / For Reed valve                               | 2                    | 62T-13566-00      | 2               | <b>007-577</b>    |
| 800 (figure 3)       | Toutes / All | Coupe flamme / Flame arrestor                                  | 2                    | 64X-13674-00      | 3               | <b>007-352</b>    |
|                      |              | Rondelles couvercle de carbura-teur / Carburetor cover O-rings | 2                    | 64X-14398-00      | 1               | <b>008-683</b>    |
|                      |              | Pour le collecteur / Manifold gasket.                          | 1                    | 66E-13556-00      | 2               | <b>007-282</b>    |

# COMPOSANTES DE MOTEUR – ENGINE COMPONENTS

## JOINTS D'ADMISSION – INTAKE GASKETS

Fig. 3

800

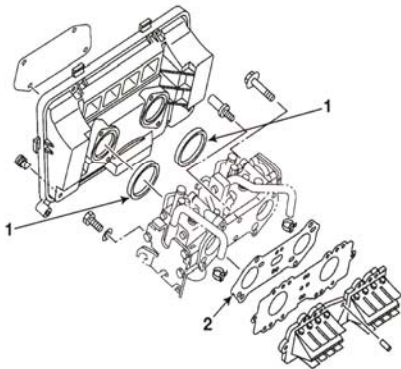

Fig. 4

1100

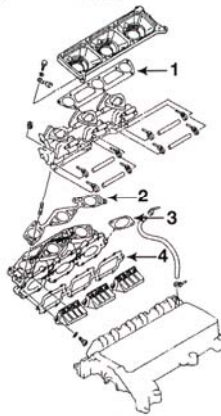

Fig. 5

1200

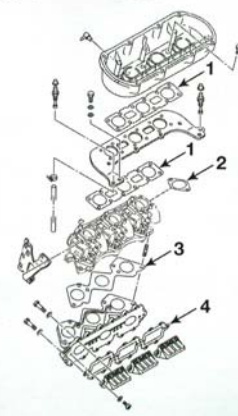
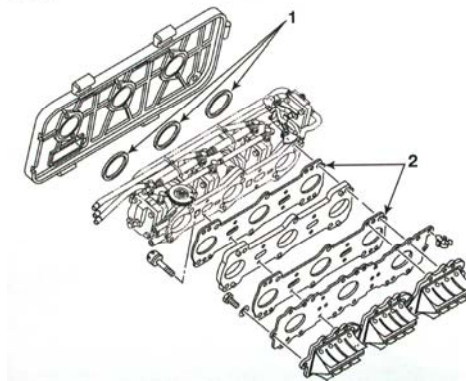

Fig. 6

1200 R



| Modèle / Model   | Année / Year | Description   | Qté req. / Req'd qty | # Origine / OEM # | # Réf. / Ref. # | # Pièce / Part #  |
|--|--------------|---|----------------------|-------------------|-----------------|-------------------|
| <b>YAMAHA</b>  |              |   |                      |                   |                 |                   |
| 1100 (63M) (figure 4)<br>Carb. Mikuni triple<br>44mm / Triple Carb.<br>Mikuni 44mm | ---          | Pour carburateur / For carburetor.                            | 3                    | 64X-14398-00      | 3               | <b>007-526</b>    |
|  |              | Collecteur d'admission / Intake manifold                      | ---                  | 63M-13556-00      | 2               | <b>007-303</b>    |
|  |              | Pour valve Reed / For Reed valve                              | 2                    | 63M-13566-00      | 4               | <b>007-304</b>    |
|  |              | Coupe flamme / Flame arrestor                                 | ---                  | 63M-13674-00      | 1               | <b>007-297</b>    |
| 1200 (65U) (figure 5)  | ---          | Pour carburateur / For carburetor.                            | 3                    | 64X-14398-00      | 2               | <b>007-526</b>    |
|  |              | Pour plaque de carburateur / Carb. plate gasket               | 1                    | 65U-13556-00      | 3               | <b>007-302</b>    |
|  |              | Pour valve Reed / For Reed valve                              | 1                    | 63M-13566-00      | 4               | <b>007-304</b>    |
|  | ---          | Coupe flamme / Flame arrestor                                 | 2                    | 65U-13674-00      | 1               | <b>007-298</b>    |
|  |              |   |                      |                   |                 |                   |
| 1200 R (66V) Moteur à soupape variable / Power valve motor.                        | ---          | Rondelles couvercle de carburateur / Carburetor cover O-rings | 3                    | 66E-13473-00      | 1 / fig.6       | <b>008-683</b>    |
|  |              | Pour collecteur / For manifold                                | 2                    | 66N-13556-00      | 2 / fig.6       | <b>007-591-01</b> |

# COMPOSANTES DE MOTEUR – ENGINE COMPONENTS

## JOINTS D'ÉCHAPEMENT – EXHAUST GASKETS

| Modèle / Model   | Année / Year    | # Réf. Ref. # | # Origine / OEM # | # Pièce Part #                   |
|--|-----------------|---------------|-------------------|----------------------------------|
| <b>KAWASAKI</b>  |                 |               |                   |                                  |
| 300 SX   | 1986-91         | ---           | 11009-3708        | <b>007-504</b>                   |
|  |                 | ---           | 11009-3750        | <b>007-507</b>                   |
|  |                 | ---           | 11009-3744        | <b>007-505</b>                   |
| 440 SX (fig. 1)  | 1977-90         | 4             | 11009-3710        | <b>007-509</b>                   |
|  |                 | 5             | 11009-3784        | <b>007-510</b>                   |
| 440 SX (fig. 1)  | 1991-92         | 4             | 11009-3779        | <b>007-515</b>                   |
|  |                 | 4             | 11009-3710        | <b>007-509</b>                   |
|  |                 | 5             | 11009-3784        | <b>007-510</b>                   |
| 550 SX (fig. 2)  | 1986-90         | 6             | 11009-3779        | <b>007-515</b>                   |
|  |                 | 7             | 11009-2462        | <b>007-518</b>                   |
|  |                 | 8             | 11009-2461        | <b>007-517</b>                   |
|  |                 | 9             | 11009-2446        | <b>007-514</b>                   |
| 550 SX (fig. 2)  | 1991-95         | 6             | 11009-3779        | <b>007-515</b>                   |
|  |                 | 7             | 11009-3777        | <b>007-542</b>                   |
|  |                 | 8             | 11009-3778        | <b>007-543</b>                   |
|  |                 | 9             | 11009-3776        | <b>007-541</b>                   |
| 650 SC (fig.3)<br>650 TS   | 1991-95         | 1             | 11060-3721        | <b>007-566</b>                   |
|  | 1991-96         | 2             | 11009-3752        | <b>007-519</b>                   |
| 650 SX (fig.3)<br>650 X2   | 1987-93         | 1             | 11060-3721        | <b>007-566</b>                   |
|  | 1989-95         | 2             | 11009-3752        | <b>007-519</b>                   |
|  | 650 TS (fig. 3) | 1989-90       | 1                 | 11060-3721                       |
| 2  |                 |               | 11009-3752        | <b>007-519</b>                   |
| 4  |                 |               | 11009-3755        | <b>007-521</b>                   |
| 5  |                 |               | 11009-3756        | <b>007-523</b>                   |
| 650 X2 (fig. 3)  | 1986-88         | 1             | 11060-3721        | <b>007-516</b>                   |
|  |                 | 2             | 11009-3723        | <b>007-519</b>                   |
|  |                 | 3             | 11009-3724        | <b>007-522</b>                   |
| 750 SS (fig. 4)  | 1992-93         | 1             | 11060-3721        | <b>007-566</b>                   |
|  |                 | 2             | 11060-3720        | <b>007-554</b>                   |
|  |                 | 4             | 11060-3718        | <b>007-556</b>                   |
|  |                 | 5             | 11060-3724        | <b>007-557</b>                   |
| 750 SS (fig. 4)<br>750 SSXI<br>750 ST<br>750 STS<br>750 Xi Sport | 1994-97         | 1             | 11060-3721        | <b>007-566</b>                   |
|  | 1993-97         | 2             | 11060-3732        | <b>007-555</b>                   |
|  | 1994-95         | 4             | 11060-3718        | <b>007-556</b>                   |
|  | 1995            | 5             | 11060-3724        | <b>007-557</b>                   |
|  | 1998-99         | 5             | 11060-3724        | <b>007-557</b>                   |
| 750 STS (fig. 4)<br>750 STX                                      | 1996-97<br>1998 | 1             | 11060-3759        | <b>007-566</b><br>2 requis/req'd |
|  |                 | 2             | 11060-3771        | <b>007-316</b><br>2 requis/req'd |
|  |                 | 3             | 92180-3704        | <b>007-321</b>                   |
|  |                 | 4             | 11060-3763        | <b>007-314</b>                   |
|  |                 | 5             | 11060-3770        | <b>007-322</b>                   |
| 750 SX (fig.5)<br>750 SXi<br>750 SXi-Pro                         | 1992-95         | 1             | 11060-3713        | <b>007-567</b>                   |
|  | 1995-96         | 2             | 11060-3714        | <b>007-564</b>                   |
|  | 1998-2002       | 3             | 11060-3712        | <b>007-565</b>                   |
|  |                 | 4             | 11060-3721        | <b>007-566</b>                   |

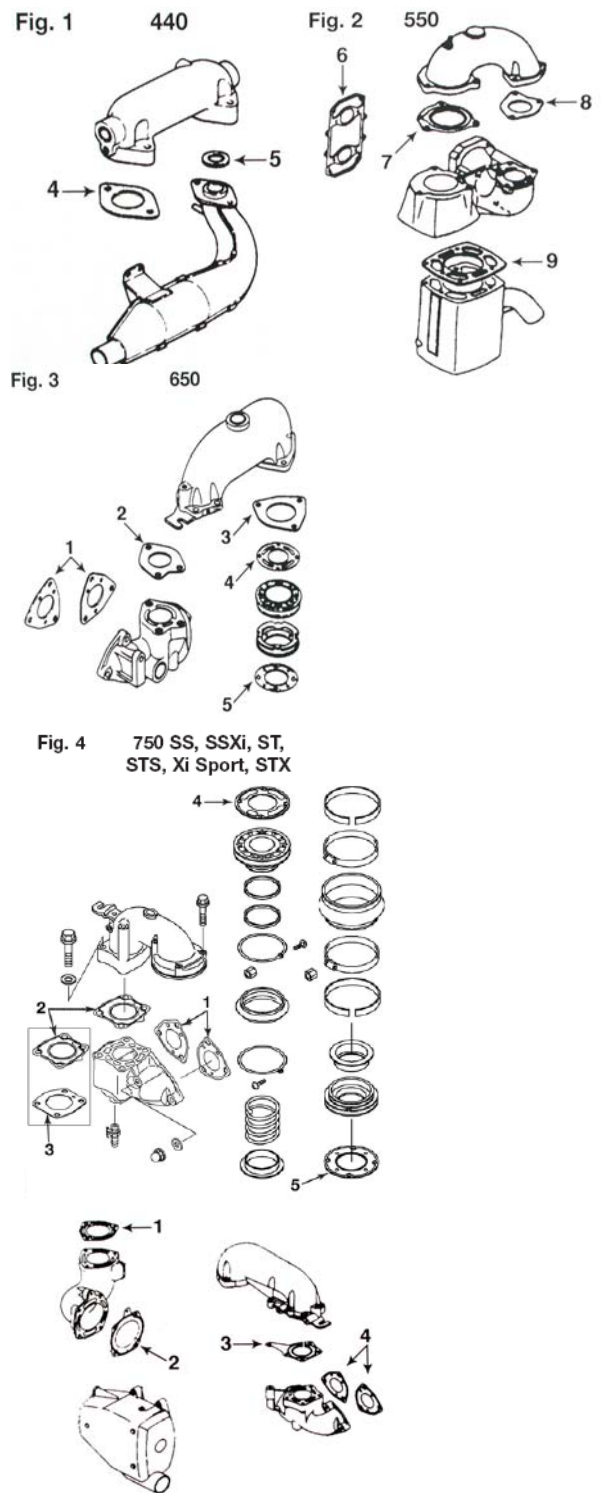

# COMPOSANTES DE MOTEUR – ENGINE COMPONENTS

## JOINTS D'ÉCHAPPEMENT – EXHAUST GASKETS

| Modèle / Model    | Année / Year | # Réf. Ref. # | # Origine / OEM # | # Pièce Part # |
|-------------------|--------------|---------------|-------------------|----------------|
| <b>KAWASAKI</b>   |              |               |                   |                |
| 750 XIR (fig.6)   | 1994         | 1             | 11060-3721        | <b>007-566</b> |
|                   |              | 2             | 11009-3752        | <b>007-519</b> |
| 750 ZXI (fig.7)   | 1995-97      | 1             | 11060-3755        | <b>007-313</b> |
|                   |              | 2             | 11060-3754        | <b>007-312</b> |
|                   |              | 3             | 11060-3759        | <b>007-566</b> |
| 800 SX-R (fig.5)  | 2003-04      | 1             | 11060-3713        | <b>007-567</b> |
|                   |              | 2             | 11060-3714        | <b>007-564</b> |
|                   |              | 3             | 11060-3712        | <b>007-565</b> |
|                   |              | 4             | 11060-3721        | <b>007-566</b> |
| 900 STX (fig.8)   | 1997-98      | 1             | 11060-3756        | <b>007-310</b> |
|                   |              | 2             | 11060-3704        | <b>007-321</b> |
|                   |              | 3             | 11060-3771        | <b>007-316</b> |
|                   |              | 4             | 11060-3777        | <b>007-323</b> |
|                   |              | 5             | 11060-3778        | <b>007-324</b> |
| 900 STS (fig. 9)  | 2001-02      | 1             | 11060-3755        | <b>007-313</b> |
| 900 STX           | 1999-2006    | 2             | 11060-3754        | <b>007-312</b> |
| 900 ZXi           | 1995-97      | 3             | 11060-3756        | <b>007-310</b> |
| 1100 STX (fig. 9) | 1997-99      | 1             | 11060-3769        | <b>007-328</b> |
| 1100 STX DI       | 2000-03      | 2             | 11060-3768        | <b>007-329</b> |
| 1100 Ultra 130 DI | 2001-04      | 3             | 11060-3767        | <b>007-332</b> |
| 1100 ZXI          | 1996-03      |               |                   |                |
| 1200 STX-R        | 2002-04      | 1             | 11060-3786        | <b>007-319</b> |
| 1200 Ultra 150    | 1999-04      | 2             | 11060-3785        | <b>007-318</b> |
| (fig. 10)         |              | 3             | 11060-3784        | <b>007-320</b> |

Fig. 6

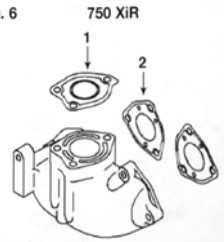

Fig. 7

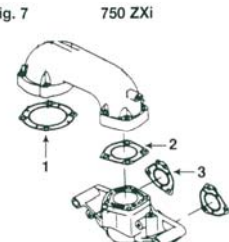

Fig. 8

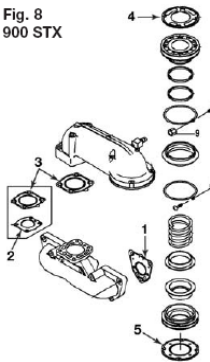

Fig. 9

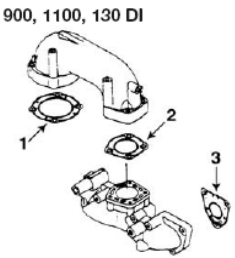
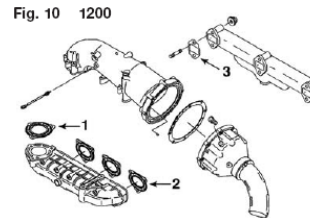

Fig. 10



| Modèle / Model | Année / Year | Description                               | Qté req. Req. qty | # Origine / OEM # | # Pièce Part #    |
|----------------|--------------|---|-------------------|-------------------|-------------------|
| <b>POLARIS</b> |              |   |                   |                   |                   |
| 650 / 750      | ---          | Tubulure d'échappement / Exhaust manifold | 1                 | 5211489           | <b>007-471</b>    |
|                |              | Tuyau d'échappement / Exhaust pipe        | 1                 | 5830038           | <b>007-470</b>    |
| 700            | ---          | Tubulure d'échappement / Exhaust manifold | 2                 | 5811045           | <b>007-471-01</b> |
|                |              | Tuyau d'échappement / Exhaust pipe        | 1                 | 5830051           | <b>007-470-01</b> |
| 780            | ---          | Tubulure d'échappement / Exhaust manifold | 1                 | 5811045           | <b>007-471-02</b> |
|                |              | Tuyau d'échappement / Exhaust pipe        | 1                 | 5830051           | <b>007-470-01</b> |
| 800 Virage     | ---          | Tubulure d'échappement / Exhaust manifold | 2                 | 5811045           | <b>007-471-01</b> |
|                |              | Tuyau d'échappement / Exhaust pipe        | 1                 | 5830051           | <b>007-470-01</b> |
| 900 / 1050     | ---          | Tubulure d'échappement / Exhaust manifold | 3                 | 5811045           | <b>007-471-01</b> |
|                |              | Tuyau d'échappement / Exhaust pipe        | 1                 | 5830051           | <b>007-470-01</b> |

# COMPOSANTES DE MOTEUR – ENGINE COMPONENTS

## JOINTS D'ÉCHAPPEMENT – EXHAUST GASKETS

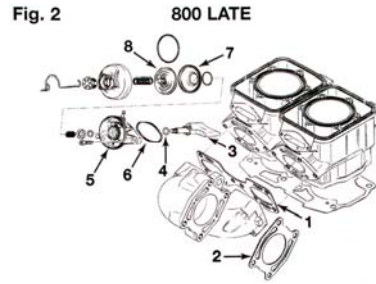
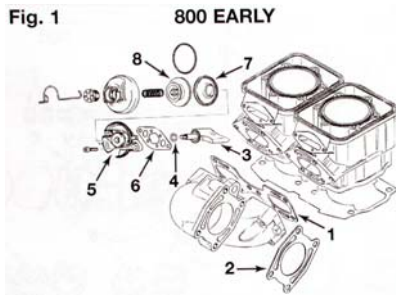

| Modèle / Model  | Année / Year                             | Description  | Qté req. / Req. qty | # Origine / OEM #               | # Pièce / Part #  |
|---|--|--|---------------------|---------------------------------|-------------------|
| <b>SEA-DOO</b>  |  |  |                     |                                 |                   |
| 587   | 1988-91                                  | Tubulure d'échappement / Exhaust manifold  | 2                   | 290-850-630                     | <b>007-551</b>    |
|   |  | Tuyau d'échappement / Exhaust pipe   | 1                   | 290-950-250                     | <b>007-553</b>    |
| 580 GTS   | 1992-96                                  | Tubulure d'échappement / Exhaust manifold  | 2                   | 290-850-635                     | <b>007-552</b>    |
|   |  | Tuyau d'échappement / Exhaust pipe   | 1                   | 290-950-250                     | <b>007-553</b>    |
| 650 / 720   | Toutes / All                             | Tubulure d'échappement / Exhaust manifold  | 2                   | 290-850-635                     | <b>007-544</b>    |
|   |  | Tuyau d'échappement / Exhaust pipe   | 1                   | 290-950-250                     | <b>007-553</b>    |
| 800 GSX<br>800 GTX<br>800 SPX<br>800 XP<br>(Fig. 1)   | 1996-97<br>1996-97<br>1997-98<br>1995-97 | Tubulure d'échappement / Exhaust manifold  | 1 (Ref. 1)          | 290-931-480 s.s<br>420-931-481  | <b>007-583</b>    |
|   |  | Tuyau d'échappement / Exhaust pipe   | 2 (Ref. 2)          | 420-931-503                     | <b>007-584</b>    |
|   |  | Soupape à alimentation variable / Power valve  | 3 (Ref. 3)          | 290-854-352 s.s.<br>420-854-358 | <b>010-495</b>    |
|   |  | Joint torique de la tige de la soupape à alimentation variable / Power valve stem O ring | 4 (Ref. 4)          | 290-430-110 s.s.<br>420-430-110 | <b>008-594</b>    |
|   |  | Logement de soupape / Valve housing  | 5 (Ref. 5)          | 290-854-360                     | <b>010-495-20</b> |
|   |  | Joint du logement / Housing gasket   | 6 (Ref. 6)          | 420-931-540                     | <b>007-585</b>    |
|   |  | Soufflets de soupape / Power valve bellows   | 7 (Ref. 7)          | 290-260-728 s.s<br>420-260-723. | <b>010-495-05</b> |
|   |  | Soupape d'échappement / Exhaust valve  | 8 (Ref. 8)          | 290-253-257 s.s.<br>420-854-449 | <b>010-495-10</b> |
| 800 GSX RFI<br>800 GTI RFI<br>800 GTX RFI<br>(Fig. 2) | 1999-01<br>2003<br>1998-99               | Tubulure d'échappement / Exhaust manifold  | 1 (Ref. 1)          | 290-931-480 s.s<br>420-931-481  | <b>007-583</b>    |
|   |  | Tuyau d'échappement / Exhaust pipe   | 2 (Ref. 2)          | 290-931-500 s.s.<br>420-931-503 | <b>007-584</b>    |
|   |  | Soupape à alimentation variable / Power valve  | 3 (Ref. 3)          | 290-854-354 s.s.<br>420-854-354 | <b>010-495</b>    |
|   |  | Joint torique de la tige de la soupape à alimentation variable / Power valve stem O ring | 4 (Ref. 4)          | 420-430-110                     | <b>008-594</b>    |
|   |  | Logement de soupape / Valve housing  | 5 (Ref. 5)          | 420-854-438                     | <b>010-495-30</b> |
|   |  | Rondelle de caoutchouc pour logement / Housing rubber ring                               | 6 (Ref. 6)          | 420-931-670                     | <b>007-585-01</b> |
|   |  | Soufflets de soupape / Power valve bellows   | 7 (Ref. 7)          | 290-260-728 s.s.<br>420-260-723 | <b>010-495-05</b> |
|   |  | Soupape d'échappement / Exhaust valve  | 8 (Ref. 8)          | 290-854-447 s.s.<br>420-854-449 | <b>010-495-10</b> |

# COMPOSANTES DE MOTEUR – ENGINE COMPONENTS

## JOINTS D'ÉCHAPPEMENT – EXHAUST GASKETS

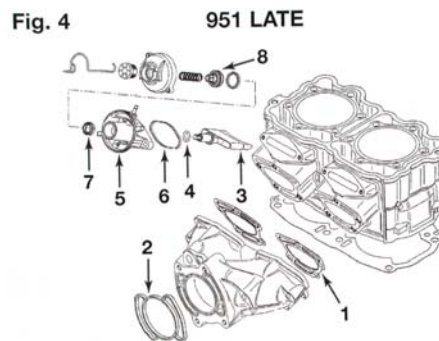
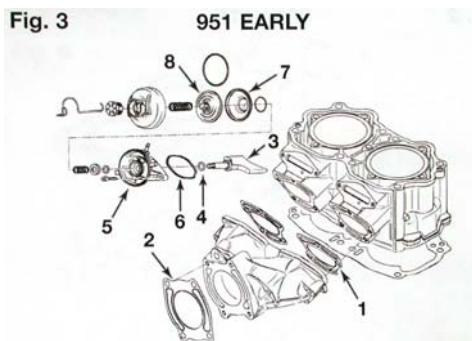

| Modèle / Model  | Année Year              | Description  | Qté req. Req. qty | # Origine / OEM #               | # Pièce Part #     |
|---|-------------------------|--|-------------------|---------------------------------|--------------------|
| <b>SEA-DOO</b>  |                         |  |                   |                                 |                    |
| 951 GSX LTD<br>(fig. 3)                                 | 1997                    | Tubulure d'échappement / Exhaust manifold  | 2 (Ref. 1)        | 293-250-081                     | <b>007-582</b>     |
|   |                         | Tuyau d'échappement./ Exhaust pipe   | 1 (Ref. 2)        | 290-931-487                     | <b>007-587-01</b>  |
|   |                         | Soupape à alimentation variable / Power valve  | 2 (Ref. 3)        | 420-854-410                     | <b>010-496</b>     |
|   |                         | Joint torique de la tige de la soupape à alimentation variable / Power valve stem O ring | 2 (Ref. 4)        | 420-430-110                     | <b>008-594</b>     |
|   |                         | Logement de soupape / Valve housing  | 2 (Ref. 5)        | 420-854-435                     | <b>010-495-25</b>  |
|   |                         | Rondelle de caoutchouc pour soupape à alimentation variable / Power valve rubber ring    | 2 (Ref. 6)        | 420-931-670                     | <b>007-585-01</b>  |
|   |                         | Soufflets de soupape / Power valve bellows   | 2 (Ref. 7)        | 290-260-728 s.s.<br>420-260-723 | <b>010-495-05</b>  |
|   |                         | Soupape d'échappement / Exhaust valve  | 2 (Ref. 8)        | 420-253-258 s.s.<br>420-854-449 | <b>010-495-10</b>  |
| 951 GSX LTD<br>951 GTX<br>951 LRV<br>951 RX<br>(Fig. 3) | 1998-99<br>2000<br>2000 | Tubulure d'échappement / Exhaust manifold  | 2 (Ref. 1)        | 293-250-081 s.s.<br>420-931-653 | <b>007-582</b>     |
|   |                         | Tuyau d'échappement./ Exhaust pipe   | 1 (Ref. 2)        | 293-250-080                     | <b>007-587</b>     |
|   |                         | Soupape à alimentation variable / Power valve  | 2 (Ref. 3)        | 420-854-410                     | <b>010-496</b>     |
|   |                         | Joint torique de la tige de la soupape à alimentation variable / Power valve stem O ring | 2 (Ref. 4)        | 290-931-765                     | <b>008-594</b>     |
|   |                         | Logement de soupape / Valve housing  | 2 (Ref. 5)        | 420-854-435                     | <b>010-495-25</b>  |
|   |                         | Rondelle de caoutchouc pour soupape à alimentation variable / Power valve rubber ring    | 2 (Ref. 6)        | 420-931-670                     | <b>007-585-01</b>  |
|   |                         | Soufflets de soupape / Power valve bellows   | 2 (Ref. 7)        | 290-260-728 s.s.<br>420-260-723 | <b>010-495-05</b>  |
|   |                         | Soupape d'échappement / Exhaust valve  | 2 (Ref. 8)        | 290-854-445 s.s.<br>420-854-446 | <b>010-495-10</b>  |
| 951 GTX<br>951 LRV<br>(Fig.3)<br>(*007-587 / Fig.4)     | 2001-02<br>2001         | Tubulure d'échappement / Exhaust manifold  | 2 (Ref. 1)        | 293-250-081 s.s.<br>420-931-653 | <b>007-582</b>     |
|   |                         | Tuyau d'échappement./ Exhaust pipe   | 1 (Ref. 2)*       | 420-931-990                     | <b>007-587-02*</b> |
|   |                         | Soupape à alimentation variable / Power valve  | 2 (Ref. 3)        | 420-854-410                     | <b>010-496</b>     |
|   |                         | Joint torique de la tige de la soupape à alimentation variable / Power valve stem O ring | 2 (Ref. 4)        | 290-931-765                     | <b>008-594</b>     |
|   |                         | Logement de soupape / Valve housing  | 2 (Ref. 5)        | 420-854-435                     | <b>010-495-25</b>  |
|   |                         | Rondelle de caoutchouc pour soupape à alimentation variable / Power valve rubber ring    | 2 (Ref. 6)        | 420-931-670                     | <b>007-585-01</b>  |
|   |                         | Soufflets de soupape / Power valve bellows   | 2 (Ref. 7)        | 290-260-728 s.s.<br>420-260-723 | <b>010-495-05</b>  |
|   |                         | Soupape d'échappement / Exhaust valve  | 2 (Ref. 8)        | 290-854-445 s.s.<br>420-854-446 | <b>010-495-10</b>  |

# COMPOSANTES DE MOTEUR – ENGINE COMPONENTS

## JOINTS D'ÉCHAPPEMENT – EXHAUST GASKETS

| Modèle / Model  | Année / Year   | Description  | Qté req. / Req. qty | # Origine / OEM # | # Pièce / Part #  |
|---|--|--|---------------------|-------------------|-------------------|
| <b>SEA-DOO</b>  |  |  |                     |                   |                   |
| 951 GTX DI<br>951 RX DI<br>(Fig. 4)<br>(*007-587 / Fig.3)                             | 2000<br>2000   | Tubulure d'échappement / Exhaust manifold  | 2 (Ref. 1)          | 420-931-653       | <b>007-582</b>    |
|   |  | Tuyau d'échappement./ Exhaust pipe   | 1 (Ref. 2)*         | 295-500-815       | <b>007-587*</b>   |
|   |  | Soupape à alimentation variable / Power valve  | 2 (Ref. 3)          | 420-854-540       | <b>010-498</b>    |
|   |  | Joint torique de la tige de la soupape à alimentation variable / Power valve stem O ring | 2 (Ref. 4)          | 420-250-460       | <b>008-594-01</b> |
|   |  | Logement de soupape / Valve housing  | 2 (Ref. 5)          | 420-854-556       | <b>010-495-31</b> |
|   |  | Rondelle de caoutchouc pour soupape à alimentation variable / Power valve rubber ring    | 2 (Ref. 6)          | 420-931-670       | <b>007-585-01</b> |
|   |  | Bague d'étanchéité / Sealing ring  | 2 (Ref. 7)          | 420-931-970       | <b>009-795</b>    |
|   |  | Soupape d'échappement / Exhaust valve  | 2 (Ref. 8)          | 450-854-560       | <b>010-495-35</b> |
| 951 GTX DI<br>951 LRV DI<br>951 RX DI<br>951 3D DI<br>951 GTX DI<br>XP DI<br>(Fig. 4) | 2001-03<br>2002<br>2001-03<br>2000<br>2001-03<br>2001-04 | Tubulure d'échappement / Exhaust manifold  | 2 (Ref. 1)          | 420-931-653       | <b>007-582</b>    |
|   |  | Tuyau d'échappement./ Exhaust pipe   | 1 (Ref. 2)          | 420-931-990       | <b>007-587-02</b> |
|   |  | Soupape à alimentation variable / Power valve  | 2 (Ref. 3)          | 420-854-540       | <b>010-498</b>    |
|   |  | Joint torique de la tige de la soupape à alimentation variable / Power valve stem O ring | 2 (Ref. 4)          | 420-250-460       | <b>008-594-01</b> |
|   |  | Logement de soupape / Valve housing  | 2 (Ref. 5)          | 420-854-556       | <b>010-495-31</b> |
|   |  | Rondelle de caoutchouc pour soupape à alimentation variable / Power valve rubber ring    | 2 (Ref. 6)          | 420-931-670       | <b>007-585-01</b> |
|   |  | Bague d'étanchéité / Sealing ring  | 2 (Ref. 7)          | 420-931-970       | <b>009-795</b>    |
|   |  | Soupape d'échappement / Exhaust valve  | 2 (Ref. 8)          | 450-854-560       | <b>010-495-35</b> |
| <b>TIGER SHARK</b>  |  |  |                     |                   |                   |
| 639 / 644   | Toutes / All   | Tubulure d'échappement / Exhaust manifold  | 2                   | 3008-384          | <b>007-579</b>    |
|   |  | Tuyau d'échappement./ Exhaust pipe   | 1                   | 3008-385          | <b>007-580</b>    |
|   |  | Pour tuyau de raccord / Connector pipe gasket  | 1                   | 3008-082          | <b>007-581</b>    |
| 770   | ---  | Tubulure d'échappement / Exhaust manifold  | 1                   | 3008-434          | <b>007-579-02</b> |
| 900 / 1000 / 1100   | ---  | Tubulure / Manifold  | 3                   | 0612-460          | <b>007-579-04</b> |
|   |  | Tubulure de refoulement / Head pipe  | 1                   | 0612-461          | <b>007-579-05</b> |
| 1000  | ---  | Pour le tuyau d'échappement arrière / Tail pipe gasket                                   | ---                 | 0612-627          | <b>007-579-07</b> |
|   |  | Pour le couvercle de la tubulure / Manifold cover gasket.                                | ---                 | 3008-519          | <b>007-580-04</b> |

500

| Modèle / Model                                 | Année / Year       | Description | Qté req. / Req'd qty | # Réf. / Ref. # | # Origine / OEM # | # Pièce / Part # |
|--|--------------------|-------------|----------------------|-----------------|-------------------|------------------|
| <b>YAMAHA</b>                                  |                    |             |                      |                 |                   |                  |
| 500 Wave Jammer<br>500 Wave Runner<br>(Fig. 1) | 1987-90<br>1987-93 | ---         | ---                  | 1               | 90430-13909       | <b>007-476</b>   |
|  |                    |             |                      | 2               | 6K8-14749-A1      | <b>007-457</b>   |
|  |                    |             |                      | 3               | 6K8-14739-A1      | <b>007-460</b>   |
|  |                    |             |                      | 4               | 6K8-14755-A1      | <b>007-451</b>   |
|  |                    |             |                      | 5               | 6K8-41114-A1      | <b>007-452</b>   |
|  |                    |             |                      | 6               | 6K8-41112-A1      | <b>007-459</b>   |
|  |                    |             |                      | 7               | 90430-08020       | <b>007-456</b>   |

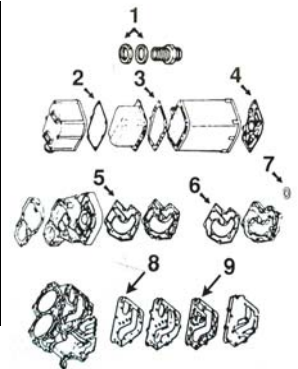

# COMPOSANTES DE MOTEUR – ENGINE COMPONENTS

## JOINTS D'ÉCHAPPEMENT – EXHAUST GASKETS

Fig. 2 650/701

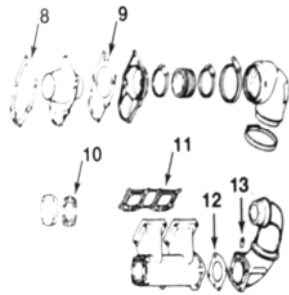

Fig. 3 701 Raider

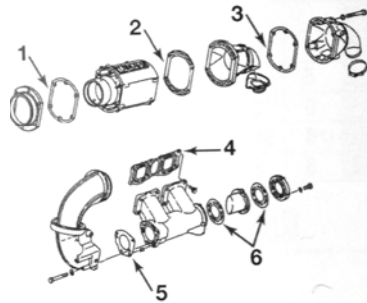
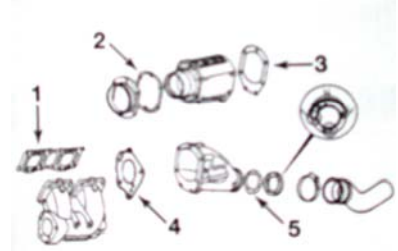

Fig. 4 760



| Modèle / Model  | Année / Year                        | Description  | Qté req. Req'd qty | # Réf. Ref. # | # Origine / OEM # | # Pièce Part # |         |
|---|-------------------------------------|--|--------------------|---------------|-------------------|----------------|---------|
| <b>YAMAHA</b>   |                                     |  |                    |               |                   |                |         |
| 500 Wave Jammer<br>500 Wave Runner<br>(Fig.1)                 | 1987-88                             | *** Pour les séries #017814 & plus / For serial #017814 & higher use.*** | ---                | 8             | 689-41114-00      | 007-454        |         |
|   | 1987-88                             |  |                    |               | 689-41112-00      | 007-458        |         |
|   |                                     |  |                    |               | 6K8-41124-00      | 007-455        |         |
| 500 Wave Jammer<br>500 Wave Runner                            | 1989                                | (Fig. 1)   | ---                | 9             | 6K8-41122-00      | 007-453        |         |
|   | 1989-93                             |  |                    |               | 1                 | 6K8-41124-00   | 007-455 |
| 650 Super Jet<br>650 WR VXR<br>650 WR III<br>(Fig.2)          | 1990-93<br>1991-95<br>1991-96       | ---  | ---                |               | 2                 | 6K8-41122      | 007-453 |
|   |                                     |  |                    |               | 8                 | 6R7-14755-00   | 007-532 |
|   |                                     |  |                    |               | 9                 | 6R7-41114-00   | 007-464 |
|   |                                     |  |                    |               | 10                | 6M6-14739-A1   | 007-461 |
|   |                                     |  |                    |               | 11                | 6M6-14613-A0   | 007-462 |
| 650 Wave Runner<br>650 Wave Runner LX<br>(Fig.2)              | 1990-93<br>1993                     | ---  | ---                |               | 12                | 6R7-14749-A0   | 007-463 |
|   |                                     |  |                    |               | 13                | 90430-08020    | 007-456 |
|   |                                     |  |                    |               | 8                 | 6M6-14755-00   | 007-530 |
|   |                                     |  |                    |               | 9                 | 6M6-41114-A0   | 007-464 |
| 701 (61X)<br>701 Super Jet<br>701 Wave Blaster<br>(Fig.2)     | Tous / All<br>1996-97<br>1993-97    | ---  | ---                |               | 10                | 6M6-14739-A1   | 007-461 |
|   |                                     |  |                    |               | 11                | 61X-14613-A1   | 007-559 |
|   |                                     |  |                    |               | 13                | 90430-08020-00 | 007-456 |
|   |                                     |  |                    |               | 12                | 6R7-14749-A0   | 007-463 |
|   |                                     |  |                    |               | 8                 | 6R7-14755-A0   | 007-532 |
| 701 62T<br>701 Wave Raider<br>701 Wave Venture<br>(Fig. 3)    | Toutes /All<br>1994-96<br>1995 +/Up | ---  | ---                |               | 9                 | 6R7-41114-A0   | 007-464 |
|   |                                     |  |                    |               | 1                 | 62T-41114-01   | 007-469 |
|   |                                     |  |                    |               | 2                 | 62T-41122-00   | 007-474 |
|   |                                     |  |                    |               | 3                 | 62T-41124-00   | 007-475 |
|   |                                     |  |                    |               | 2                 | 62T-14739-00   | 007-467 |
| 701 Wave Runner III GP<br>701 Wave Runner PRO VXR<br>(Fig. 2) | 1994-95<br>1993-94                  | ---  | ---                |               | 4                 | 62T-14613-00   | 007-465 |
|   |                                     |  |                    |               | 5                 | 62T-14749-00   | 007-468 |
|   |                                     |  |                    |               | 10                | 6M6-14739-A1   | 007-461 |
|   |                                     |  |                    |               | 11                | 61X-14613-A0   | 007-559 |
|   |                                     | ---  | ---                |               | 13                | 9043-08020-00  | 007-456 |
|   |                                     |  |                    |               | 12                | 6R7-14749-A0   | 007-463 |
|   |                                     |  |                    |               | 9                 | 6R7-41114-A0   | 007-464 |

# COMPOSANTES DE MOTEUR – ENGINE COMPONENTS

## JOINTS D'ÉCHAPPEMENT – EXHAUST GASKETS

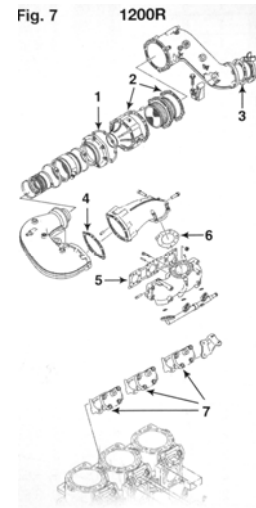
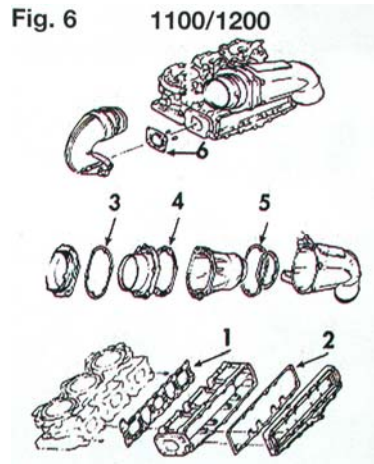
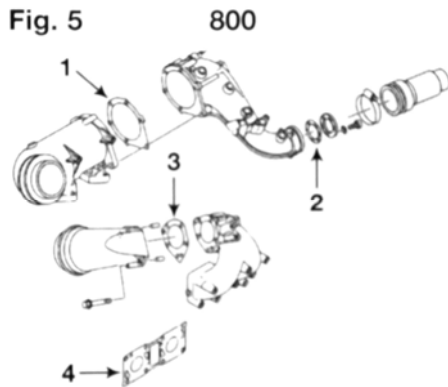

| Modèle / Model                                    | Année / Year | Description   | Qté req. Req'd qty | # Réf. Ref. #  | # Origine / OEM # | # Pièce Part #    |                   |
|---|--------------|---|--------------------|----------------|-------------------|-------------------|-------------------|
| <b>YAMAHA</b>                                     |              |   |                    |                |                   |                   |                   |
| 760<br>(Fig.4)                                    | Toutes / All | ---   | ---                | 1              | 62T-14613-00      | <b>007-465</b>    |                   |
|   |              |   |                    | 4              | 64X-14749-00      | <b>007-353</b>    |                   |
|   |              |   |                    | 3              | 64X-41124-00      | <b>007-354</b>    |                   |
|   |              |   |                    | 2              | 62T-41114-01      | <b>007-469</b>    |                   |
|   |              |   |                    | 5              | 64X-14623-00      | <b>007-356</b>    |                   |
| 800<br>(Fig. 5)                                   | ---          | Tuyau d'échappement / Exhaust pipe  | ---                | 4              | 66E-14613-00      | <b>007-283</b>    |                   |
|   |              | Tuyau d'échappement / Exhaust pipe  |                    | 2              | 66E-14623-00      | <b>007-284</b>    |                   |
|   |              | Pour la sourdine du silencieux / Muffler damp                               |                    | 3              | 66E-14749-00      | <b>007-285</b>    |                   |
|   |              | Pour l'extérieur de l'échappement / Exhaust outer                           |                    | 1              | 66E-41124-10      | <b>007-286</b>    |                   |
| 1100<br>(Fig. 6)                                  | Toutes / All | ---   | ---                | 2              | 62T-41114-01      | <b>007-469</b>    |                   |
|   |              |   |                    | 5              | 64X-14623-00      | <b>007-356</b>    |                   |
|   |              |   |                    | 1              | 63M-14613-00      | <b>007-305</b>    |                   |
|   |              |   |                    | 2              | 63M-14739-00      | <b>007-290</b>    |                   |
|   |              |   |                    | 6              | 63M-14749-00      | <b>007-291</b>    |                   |
|   |              |   |                    | 2              | 3 & 5             | 63M-41114-00      | <b>007-292</b>    |
|   |              |   |                    | ---            | 4                 | 63M-41122-00      | <b>007-293</b>    |
| 1200<br>(Fig. 6)                                  | ---          | ---   | ---                | 4              | 63M-41122-00      | <b>007-293</b>    |                   |
|   |              |   |                    | 1              | 65U-14613-00      | <b>007-306</b>    |                   |
|   |              |   |                    | 2              | 63M-14739-00      | <b>007-290</b>    |                   |
|   |              |   |                    | 2              | 3 & 5             | 63M-41114-00      | <b>007-292</b>    |
|   |              |   |                    | ---            | 6                 | 63M-14749-00      | <b>007-291</b>    |
| 1200R<br>(Fig. 7)                                 | ---          | Tuyau d'échappement / Exhaust pipe  | ---                | 5              | 66V-14613-00      | <b>007-592</b>    |                   |
|   |              |   |                    | 3              | 66V-14623-00      | <b>007-596-01</b> |                   |
|   |              | Pour la sourdine du silencieux / Muffler damp                               |                    | ---            | 6                 | 66V-14739-00      | <b>007-595-01</b> |
|   |              |   |                    | 4              | 66V-14749-00      | <b>007-590</b>    |                   |
|   |              | Pour le couvercle de la soupape à alimentation variable / Power valve cover |                    | 3              | 7                 | 66E-1131B-01      | <b>007-595</b>    |
|   |              | Pour l'extérieur de l'échappement / Exhaust outer                           |                    | ---            | 1                 | 66V-41114-00      | <b>007-590-01</b> |
| Pour l'extérieur de l'échappement / Exhaust outer | 2            | 2   | 66V-41124-00       | <b>007-591</b> |                   |                   |                   |

# COMPOSANTES DE MOTEUR – ENGINE COMPONENTS

## PIÈCES POUR LE TUYAU D'ÉCHAPPEMENT / EXHAUST PARTS

| Modèle / Model   | Année / Year | Description                       | # Origine / OEM # | # Pièce / Part # |
|------------------|--------------|-----------------------------------|-------------------|------------------|
| <b>YAMAHA</b>    |              |                                   |                   |                  |
| 701 Wave Venture | 1995-96      | Tuyau d'évacuation / Exhaust hose | 63N-14752-30      | <b>011-500</b>   |



**011-500**

| Modèle / Model                                    | Année / Year                                     | Description  | # Origine / OEM # | # Pièce / Part # |
|---|--|--|-------------------|------------------|
| <b>KAWASAKI</b>                                   |  |  |                   |                  |
| 650 SX<br>650 X2<br>650 Jet Mate                  | 1987-93<br>1987-94<br>1989-92                    | Épaulement d'échappement / Exhaust flange            | 92059-3767        | <b>011-508</b>   |
| 650 X2<br>650 SX<br>650 Jet Mate                  | 1987-94<br>1987-93<br>1989-92                    | Conduit d'échappement (petit) / Exhaust hose (small) | 92059-3706        | <b>011-509</b>   |
| 650 TS<br>750 SS<br>750 SSXI<br>750 XI            | 1989-96<br>1992-97<br>1993-97<br>1998-99         | Coupleur d'échappement / Exhaust coupler             | 92190-3712        | <b>011-510</b>   |
| 650 TS<br>650 SC                                  | 1989-96<br>1991-95                               |  | 92093-3732        | <b>011-511</b>   |
| 750 SS<br>750 SSXI<br>750 XI<br>750 ST<br>750 STS | 1992-97<br>1993-97<br>1998-99<br>1994-95<br>1995 | Épaulement / Exhaust diffusers                       | 92093-3738        | <b>011-519</b>   |
| 750 STS<br>750 STX                                | 1996-97<br>1998                                  | Épaulement / Exhaust diffusers                       | 92191-3733        | <b>011-517</b>   |
| 750 STS<br>750 STX                                | 1996-97<br>1998                                  | Épaulement / Exhaust diffusers                       | 92093-3744        | <b>011-518</b>   |



**011-508**

**011-509**



**011-510**

**011-511**



**011-512**

**011-513**

## PIÈCES POUR LE TUYAU D'ÉCHAPPEMENT / EXHAUST PARTS

| Modèle / Model                              | Année / Year | Description                    | # Origine / OEM # | # Pièce / Part # |
|---|--------------|--------------------------------|-------------------|------------------|
| <b>KAWASAKI</b>                             |              |                                |                   |                  |
| 900 STX                                     | 1997-98      | Épaulement / Exhaust diffusers | 92191-3811        | <b>011-512</b>   |
| 900 STX                                     | 1997-98      | Épaulement / Exhaust diffusers | 92093-3751        | <b>011-513</b>   |
| <b>SEA-DOO</b>                              |              |                                |                   |                  |
| Coussinets d'échappement / Exhaust bushings |              |                                | 293-830-031       | <b>011-515</b>   |
|   |              |                                | 274-000-114       | <b>011-516</b>   |



**011-515**



**011-516**

# COMPOSANTES DE MOTEUR – ENGINE COMPONENTS

## COUVERCLE DE GÉNÉRATEUR / GENERATOR COVER ANNEAUX & JOINTS D'ÉTANCHÉITÉ / GASKETS & O-RINGS

| Modèle / Model         | Année / Year       | Description                                | # Origine / OEM # | # Pièce / Part #  |
|------------------------|--------------------|--|-------------------|-------------------|
| <b>KAWASAKI</b>        |                    |  |                   |                   |
| 440 SX<br>550 SX       | 1977-90<br>1982-94 | ---  | 92055-520         | <b>008-430</b>    |
| 440 SX<br>550 SX       | 1982-91<br>1986-94 | ---  | 92055-521         | <b>008-417</b>    |
| 650, 750,<br>900, 1100 | Toutes / All       | ---  | 92055-3712        | <b>008-418</b>    |
| 1200                   | Toutes / All       | ---  | 92055-3748        | <b>008-420</b>    |
| <b>POLARIS</b>         |                    |  |                   |                   |
| 650, 750, 780          | ---                | ---  | 3240045           | <b>007-473</b>    |
| 700, 900,<br>1050      | ---                | ---  | 5811145           | <b>007-473-01</b> |
| 800                    | ---                | ---  | 3569806           | <b>007-473-02</b> |
| <b>SEA-DOO</b>         |                    |  |                   |                   |
| 580                    | 1989-91            | ---  | 290-950-130       | <b>008-581</b>    |
| 580                    | 1992 & +           | ---  | 290-831-555       | <b>008-588</b>    |
| 650, 720               | Toutes / All       | ---  | 290-831-555       | <b>008-588</b>    |
| 800                    | Toutes / All       | ---  | 290-950-360       | <b>008-613</b>    |
| 951                    | Toutes / All       | ---  | 290-931-690       | <b>008-612</b>    |
| <b>TIGER SHARK</b>     |                    |  |                   |                   |
| 900, 1000,<br>1100     | ---                | Boîtier magneto /<br>Magneto case          | 3008-259          | <b>007-447</b>    |
| 1000                   | 1998               | Couvercle de<br>magneto / Magneto<br>cover | 3008-260          | <b>007-448</b>    |

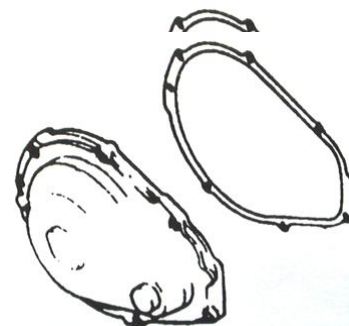
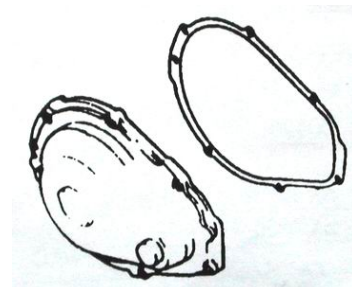

## COUVERCLE DE GÉNÉRATEUR / GENERATOR COVER ANNEAUX & JOINTS D'ÉTANCHÉITÉ / GASKETS & O-RINGS

| Modèle / Model | Année / Year | Description | # Origine / OEM # | # Pièce / Part # |
|----------------|--------------|-------------|-------------------|------------------|
| <b>YAMAHA</b>  |              |             |                   |                  |
| 500            | Toutes / All | ---         | 6K8-81365-A1      | <b>007-479</b>   |
| 650, 701, 760  | Toutes / All | ---         | 6M6-81365-A0      | <b>007-480</b>   |
| 1100, 1200     | Toutes / All | ---         | 63M-81365-00      | <b>007-295</b>   |

# COMPOSANTES DE MOTEUR – ENGINE COMPONENTS

## ANNEAUX & JOINTS D'ÉTANCHÉITÉ DIVERS MISCELLANEOUS GASKETS & O-RINGS

| Modèle / Model                  | Année / Year                  | Description   | # Origine / OEM #      | Qté req. / Req. qty. | # Pièce / Part #                 |
|---------------------------------|-------------------------------|---|------------------------|----------------------|----------------------------------|
| <b>KAWASAKI</b>                 |                               |   |                        |                      |                                  |
| 440, 550, 650<br>750            | ---                           | Anneau pour bouchon d'huile / Oil cap O-ring                            | 92055-515<br>92055-049 | ---                  | <b>008-416</b><br><b>008-607</b> |
| 300 SX<br>440 SX<br>550 SX      | 1986-89<br>1982-92<br>1986-94 | Anneau pour carter de moteur / Crank case O-ring                        | 670B-2016              | ---                  | <b>008-415</b>                   |
| 440 SX<br>550 SX                | 1982-92<br>1986-94            | Joint pour boîtier électrique / Electric case gasket                    | 11009-3045             | ---                  | <b>007-490</b>                   |
| 650                             | 1986-90                       | Joint pour boîtier électrique / Electric case gasket                    | 11060-3708             | ---                  | <b>007-502</b>                   |
|                                 | 1991-93                       |   | 11060-3707             |                      | <b>007-491</b>                   |
| <b>POLARIS</b>                  |                               |   |                        |                      |                                  |
| 650<br>750<br>780               | ---                           | Anneau de pompe à huile / Oil pump O-ring                               | 5410613                | ---                  | <b>008-661</b>                   |
|                                 |                               | Joint de boîtier de thermostat / Thermostat housing gasket              | 5410781                | 1                    | <b>007-472</b>                   |
|                                 |                               | Anneau pour thermostat / Thermostat O-ring                              | 5410860                | 1                    | <b>008-617</b>                   |
|                                 |                               | Joint de collecteur d'eau / Water manifold gasket                       | 3082937                | 3                    | <b>007-537</b>                   |
| 700<br>900<br>1050              | ---                           | Joint de collecteur d'eau / Water manifold gasket                       | 5830061                | ---                  | <b>007-537-01</b>                |
|                                 |                               | Anneau de pompe à l'huile / Oil pump O-ring                             | 5411056                |                      | <b>008-660</b>                   |
|                                 |                               | Anneau de vilebrequin / Crankshaft O-ring                               | 5410613                |                      | <b>008-661</b>                   |
| <b>SEA-DOO</b>                  |                               |   |                        |                      |                                  |
| 580 (jaune / Yellow)            | 1988-91                       | Joint du boîtier Magneto (4 trous)/Magneto housing gasket (4 holes)     | 290-850-600            | ---                  | <b>007-572</b>                   |
| 580 (blanc / white)<br>650, 720 | Toutes / All                  | Joint du boîtier Magneto (8 trous)/Magneto housing gasket (8 holes)     | 290-850-605            | ---                  | <b>007-576</b>                   |
| 800                             | Toutes / All                  | Joint du boîtier ignition / Ignition housing gasket                     | 290-831-470            | ---                  | <b>007-586</b>                   |
| 580, 650<br>580<br>580<br>951   | 1988-94                       | Joint de démarreur / Starter gasket                                     | 290-830-905            | ---                  | <b>007-570</b>                   |
|                                 | 1988-90                       | Joint de pompe à eau / Water pump gasket                                | 290-831-615            |                      | <b>007-573</b>                   |
|                                 | 1991<br>---                   | Anneau de pompe à eau / Water pump O-ring                               | 293-300-021            |                      | 2                                |
| <b>TIGER SHARK</b>              |                               |   |                        |                      |                                  |
| 640                             | ---                           | Joint de thermostat / Thermostat gasket                                 | 3008-230               | 1                    | <b>007-538-02</b>                |
| <b>YAMAHA</b>                   |                               |   |                        |                      |                                  |
| 500                             | ---                           | Joint de thermostat / Thermostat gasket                                 | 655-12414-A1           | 1                    | <b>007-477</b>                   |
|                                 |                               | Joint de la moitié supérieure du carter moteur / Upper crankcase gasket | 689-45113-01           | 1                    | <b>007-489</b>                   |
|                                 |                               | Joint du boîtier / Housing gasket                                       | 6K8-15369-A1           | ---                  | <b>007-478</b>                   |

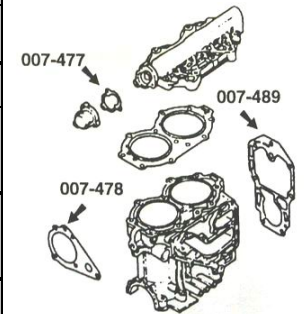
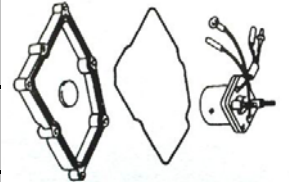
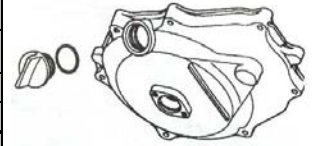

# COMPOSANTES DE MOTEUR – ENGINE COMPONENTS

## PIÈCES POUR LA POMPE À L'HUILE / OIL PUMP PARTS

### ANNEAUX & JOINTS DE POMPE À L'HUILE / OIL PUMP O-RINGS & GASKETS



| Modèle / Model  | Description     | # Origine / OEM # | # Pièce / Part # |
|-----------------|-----------------|-------------------|------------------|
| <b>KAWASAKI</b> |                 |                   |                  |
| 650             | Anneau / O-ring | 92055-055         | <b>008-410</b>   |
| <b>POLARIS</b>  |                 |                   |                  |
| 650, 750, 780   | Anneau / O-ring | 3083127           | <b>008-661</b>   |
| 700, 900, 1050  | Anneau / O-ring | 5411056           | <b>008-660</b>   |

## PIÈCES POUR LA POMPE À L'HUILE / OIL PUMP PARTS

### ANNEAUX & JOINTS DE POMPE À L'HUILE / OIL PUMP O-RINGS & GASKETS

| Modèle / Model                | Description     | # Origine / OEM # | # Pièce / Part # |
|-------------------------------|-----------------|-------------------|------------------|
| <b>SEA-DOO</b>                |                 |                   |                  |
| Tous les modèles / All models | Anneau / O-ring | 293-300-018       | <b>008-587</b>   |
| <b>YAMAHA</b>                 |                 |                   |                  |
| 650, 701, 760                 | Joint / Gasket  | 6R8-13116-00      | <b>007-533</b>   |
| 1200                          | Joint / Gasket  | 63M-13116-00      | <b>007-296</b>   |

## PLAQUE DE BLOCAGE D'INJECTION À L'HUILE OIL INJECTION BLOCK OFF PLATES

Billette en aluminium noir anodisé / Billet aluminum black anodized

| Modèle / Model  | Année / Year | # Pièce / Part # |
|-----------------|--------------|------------------|
| <b>KAWASAKI</b> |              |                  |
| 650, 750        | Toutes / All | <b>011-205</b>   |
| 900, 1100       |              | <b>011-206</b>   |
| <b>POLARIS</b>  |              |                  |
| 650, 750, 780   | ---          | <b>011-208</b>   |
| 700, 900, 1050  |              | <b>011-211</b>   |
| <b>SEA-DOO</b>  |              |                  |
| 580, 650, 720   | ---          | <b>011-212</b>   |
| 800, 951        |              | <b>011-213</b>   |



011-211

# COMPOSANTES DE MOTEUR – ENGINE COMPONENTS

## PLAQUE DE BLOCAGE D'INJECTION À L'HUILE OIL INJECTION BLOCK OFF PLATES

Billette en aluminium noir anodisé / Billet aluminum black anodized

| Modèle / Model   | Année / Year | # Pièce / Part # |
|--|--------------|------------------|
| <b>TIGER SHARK</b>   |              |                  |
| Barracuda<br>Daytona 770<br>Montego<br>Montego Dlx<br>Monte Carlo 640, 770 | ---          | 011-214          |
| Daytona 1000<br>Monte Carlo 900<br>Monte Carlo 1000                        | ---          | 011-211          |
| <b>YAMAHA</b>  |              |                  |
| 650, 701, 760  | ---          | 011-205          |
| 1100, 1200   |              | 011-216          |
| 800, 1200R   |              | 011-206          |



011-211

## PLAQUE DE BLOCAGE DE CARTER / CRANK CASE BLOCK OFF PLATE

| Modèle / Model  | # Pièce / Part # |
|-----------------|------------------|
| <b>KAWASAKI</b> |                  |
| 650, 750        | 011-210          |



## PIÈCES DE ROTATION SEA-DOO / SEA-DOO ROTARY PARTS

### ARBRE DE ROTATION / ROTARY SHAFT

010-455

010-457

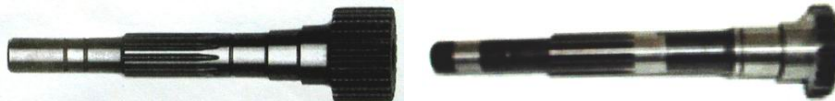

### ENGRENAGE EN CUIVRE BRASS GEAR

010-450



| Modèle / Model  | Année / Year | # Origine / OEM # |
|-----------------|--------------|-------------------|
| 580 / 650 / 720 | Toutes / All | 290-837-251       |

| Modèle / Model | Année / Year | # Origine / OEM # |
|----------------|--------------|-------------------|
| 800            | ---          | 290-837-351       |

| Modèle / Model        | Année / Year | # Origine / OEM # |
|-----------------------|--------------|-------------------|
| 580 / 650 / 720 / 800 | Toutes / All | 420-935-735       |

# COMPOSANTES DE MOTEUR – ENGINE COMPONENTS

## PIÈCES DE ROTATION SEA-DOO / SEA-DOO ROTARY PARTS

### RESSORT / SPRING

010-453



| Modèle / Model        | Année / Year | # Origine / OEM # |
|-----------------------|--------------|-------------------|
| 580 / 650 / 720 / 800 | Toutes / All | 290-938-810       |

### SUPPORT À RESSORT / SPRING HOLDER

010-484-01



| Modèle / Model        | Année / Year | # Origine / OEM # |
|-----------------------|--------------|-------------------|
| 580 / 650 / 720 / 800 | Toutes / All | 420-827-430       |

### ANNEAU D'ÉTANCHÉITÉ / SHAFT OIL SEAL

009-779



| Modèle / Model        | Année / Year | # Origine / OEM # |
|-----------------------|--------------|-------------------|
| 580 / 650 / 720 / 800 | Toutes / All | 290-930-580       |

### ROULEMENT DU BOÎTIER / CASE BEARING

010-226



| Modèle / Model        | Année / Year | # Origine / OEM # |
|-----------------------|--------------|-------------------|
| 580 / 650 / 720 / 800 | Toutes / All | 290-932-797       |

### ROULEMENT DE L'ARBRE / SHAFT BEARING

010-225



| Modèle / Model        | Année / Year | # Origine / OEM # |
|-----------------------|--------------|-------------------|
| 580 / 650 / 720 / 800 | Toutes / All | 290-932-032       |

### RONDELLE DU ROULEMENT / BEARING WASHER

010-459



| Modèle / Model        | Année / Year | # Origine / OEM # |
|-----------------------|--------------|-------------------|
| 580 / 650 / 720 / 800 | Toutes / All | 420-227-439       |

### GAINÉ À ARBRE / ROTARY SHAFT BARREL

010-484



| Modèle / Model  | Année / Year | # Origine / OEM # |
|-----------------|--------------|-------------------|
| 580 / 650 / 720 | Toutes / All | 290-847-282       |

### ANNEAU DE L'ARBRE / ROTARY SHAFT O-RING

008-609



| Modèle / Model              | Année / Year | # Origine / OEM # |
|-----------------------------|--------------|-------------------|
| 580 / 650 / 720 / 800 / 951 | Toutes / All | 293-300-024       |

# COMPOSANTES DE MOTEUR – ENGINE COMPONENTS

## PIÈCES DE ROTATION SEA-DOO / SEA-DOO ROTARY PARTS

### ROUE D'ALLUMAGE - TIMING WHEEL

**TW170**

Permet l'ajustement recommandé de la valve rotative pour Sea-Doo.  
Enables recommended adjustment of the rotary valve, for Sea-Doo.



### ANNEAU DE RETENUE / RETAINING RING

Retient l'arbre dans le moteur.  
Keeps shaft in engine.

S'installe sur l'arbre.  
Goes on shaft.

**010-482**

**010-483**



### SEGMENTS / CIRCLIPS

S'installe sur l'arbre.  
Goes on shaft.

**010-454**

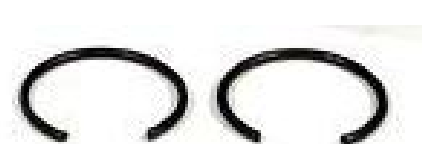

| Modèle / Model              | Année / Year | # Origine / OEM # |
|-----------------------------|--------------|-------------------|
| 580 / 650 / 720 / 800 / 951 | Toutes / All | ---               |

| Modèle / Model              | Année / Year | # Origine / OEM # |
|-----------------------------|--------------|-------------------|
| 580 / 650 / 720 / 800 / 951 | Toutes / All | 290-845-260       |

| Modèle / Model              | Année / Year | # Origine / OEM # |
|-----------------------------|--------------|-------------------|
| 580 / 650 / 720 / 800 / 951 | Toutes / All | 290-845-160       |

### PIÈCE DE SOUPAPE DE PUISSANCE / POWER VALVE PARTS

| Modèle / Model    | # Origine / OEM # | # Pièce / Part # |
|-------------------|-------------------|------------------|
| 800 RFI           | 420-854-354       | <b>010-494</b>   |
| 800 Carb. (96-99) | 420-854-358       | <b>010-495</b>   |
| 951 Carb. (99-02) | 290-854-410       | <b>010-496</b>   |
| 951 DI (03-06)    | 420-854-540       | <b>010-498</b>   |



### VALVE ROTATIVE EN ACIER INOXYDABLE / STAINLESS STEEL ROTARY VALVE

| Description  | # Pièce / Part # |
|--|------------------|
| 147 ° degré / degree (plus de partie inférieure / more bottom end) | <b>006-147</b>   |
| 159 ° degré / degree (pièce de remplacement / replacement stock)   | <b>006-159</b>   |



**006-147**

N.B. Mêmes applications que ci-dessous / Same applications as below.